

Constructing a base

As with all buildings, timber garden buildings require a firm level base if they are to remain sound and serviceable. Without the correct base, even the best-made buildings will quickly deteriorate. The walls and roof will sag and the door will jam. The lower timbers in the wall will remain wet whilst the floor will rot through being in permanent contact with the ground. This document explains how to build a suitable base including how to make formwork (wooden framework constructed to form concrete pad), prepare and lay concrete.



SELECT SUITABLE SITE

Try to visualise what the building will look like in the position selected. Make sure that access is going to be adequate for the intended usage. Do you want to have to drag that large or heavy object right down to the end of your garden? You could always site the building closer to the house. Take into account the distance from the site to the closest electricity and water points etc. Once the base has been constructed, it is very difficult to change the site. Please remember, we cannot construct our buildings on an poorly constructed base. It is well worth while taking special care and a small amount of time to ensure a good base is constructed. This will reap benefits in years to come.

DESIGN A BASE

Your base can take several forms, these need not be too elaborate. However, whatever method is employed, it is essential that the end result is above all firm, level and square. It could be constructed of paving slabs, blocks or timber bearers. However, the most satisfactory solution is to construct a solid concrete slab to the correct size for the building. Bricks are not recommended unless set onto an existing base as they can sink individually. Problems which arise do so as a result of an inadequate base.

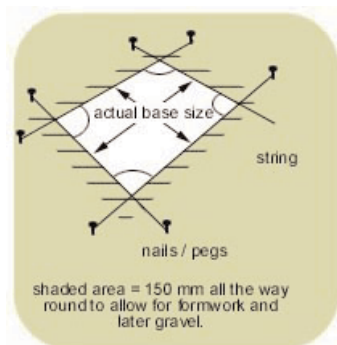

TIMBER BEARERS

We can supply 3" x 2" (75mm x 50mm) tanalised treated timber bearers complete with a damp proof course. We can lay these straight onto your ready prepared level site when we assemble your new building. These are advantageous as they will raise your building off the base altogether, stopping any damp from rising and encourages air circulation. We recommend their use when your base is larger than the size of the building's floor.

If you have an area of firm, level ground, these bearers could form your base. All you would need to do, would be to clear all vegetation from the selected site and carefully level and compact the soil. A 2" (50mm) layer of Pea Shingle laid on top will allow good drainage.

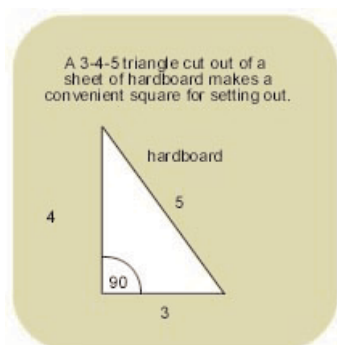

ROWS OF BLOCKS OR PAVING SLABS

You can site your new building on rows of blocks or paving slabs. It is important that they are laid in complete rows across the width of the building (ie, at right angles to the pent or apex shaped end. Floor battens always run from shaped end to shaped end.) If your shed is the transverse (ie. 8'x12' instead of 12'x8') please ask for a floor plan. The same principle will apply if you are laying your own timber or concrete bearers.

These rows may be up to 2' apart, however it is important that you have a row where two-piece floor sections abut each other (if appropriate.) On buildings with a floor size over 8'x 7' up to 12' x 8', the floors generally come in two equal halves, so there must obviously be a row centrally. On buildings over 12' x 8' the number of floors may vary, so please check with the factory.

Remove all vegetation from the site and carefully level the overall area. Lay the supports, one at each end and correctly spaced in-between, ensuring each support is level to the next by using a spirit-level and a straight edge. Ensure these supporting rows are set on a firm sub-base and bed them onto a sand/cement dry-mix. They must be level over the whole site in order to spread the load equally and avoid any of the base sinking.

CONCRETE SLABS OR PATIO AREAS

Many customers will have existing patios or old shed bases on which they may site the building. However please do check these are level and suitable. If the intended site is larger than the size of the building, we recommend it is raised off the base. This is in order to stop any puddles formed from soaking the floor. We can supply 3" x 2" (75mm x 50mm) tanalised treated timber bearers with DPC which are ideal for this purpose.

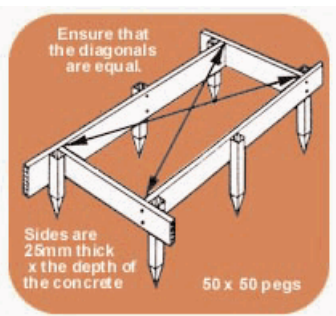

Some customers will require a new base to be constructed. However, unless the customer is keen and competent in DIY, this is an area where a good local builder is best employed. The site where you ordered your new building may be able to recommend one. However if you do build it yourself, we offer some advice.

Cut back any infringing trees and bushes. Allow at least 12" (300mm) all around and 36"-48" above the roof of the building. The base must be firm, level, square and designed to suit the floor size of the selected building. Obtain the exact base size and add 1" (25mm) to length and width and use these dimensions to set out the base.

Mark 6" all around the outside of this area for the overall size of the 'dig'. Check this is square by measuring the diagonals. Carefully mark out the exact size of the required shed base, using pegs and string.

Remove the setting out strings, but leave the pegs in place for further use. Remove all vegetation and clear the topsoil to the depth required. Carefully level and compact the ground. For ordinary garden sheds, a thickness of 3" (75mm) is sufficient in most situations. On soft clay, or on larger buildings, increase the thickness to 4" (100mm) laid on 2" (50mm) of finely broken and compacted hard-core if required. Half the depth of the base (approx) should be above ground level.

Replace the setting out strings on the pegs and check the original measurements. Check the markings are still square by checking the diagonals. These strings are used for positioning the concrete formwork. This is made from 1" (25mm) thick timber and should be as wide as the depth of the concrete slab.

Use a tape measure, spirit-level and try-square to set off the formwork accurately. This is nailed onto pegs driven into the ground. These pegs should be sited on the outside of the formwork in each corner and every 2' (600mm)

It is very important that the pegs do not protrude above the top of the formwork as this will make the levelling off of the concrete very difficult. Ensure the top of the formwork is carefully checked and is level all around (use a long spirit level).

Concrete is a mixture of 'all-in' ballast, Portland cement and water. For this type of base, they are mixed to the ratio of:

1 Part cement
5 Parts 'all-in' ballast.

BALLAST

'All-in' ballast (20mm) is usually sold in 40kg bags at your local builders merchant or DIY superstore. 1.25 bags are needed to produce approx. 1 cubic foot of concrete. Therefore, the formula to calculate the amount of ballast required is as follows:

Example:

Shed Base = 8' long x 6' wide x 3" deep.

Volume = 8' x 6' x 0.25' = 12 cu ft

Add 1/3 for compacting = 4 cu ft

'All-in' ballast required = 16 cu ft

16 x 1.25 = 20 bags of 20mm 'all-in' ballast.

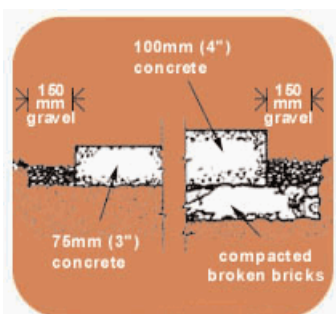

Quantities for other size bases may be worked out using these figures. The golden rule is to order on the generous size when buying materials. Excavations can seldom be measured accurately.

CEMENT

1 bag (50kg) of cement mixed with 'all-in' ballast in the ratio of 1.5 makes:
24 sq ft of concrete 3" thick or 18 sq ft of concrete 4" thick for 8' x 6' (48 sq ft)
3" thick base cement = 2 bags for 8' x 6' (48 sq ft)
4" thick base cement = 3 bags

Quantities for other size bases may be worked out using these figures.

MIXING

Try to mix alongside the base site so that the concrete can be placed by shovel, otherwise use a wheelbarrow. Use a plastic bucket (3 gallon) for accurately measuring materials. Use another bucket for measuring water.

Mix well in the proportion:

1 bucket of cement
5 buckets 'all-in' 20mm ballast.

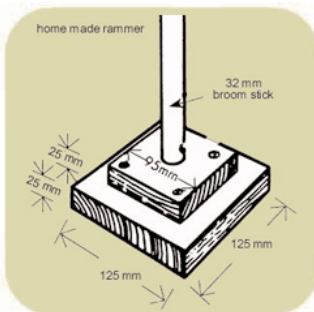

Add water gradually to the mix until the whole pile is uniform in colour and sufficiently workable to use. Do not make the mix too wet - this weakens the concrete. Note how much water has been used and use the same quantity for each mix. Hire a cement mixer for making large quantities of concrete.

LAYING CONCRETE

Place a layer of concrete into the formwork. Compact this down with a rammer, taking particular care to push the concrete into the corners and edges.

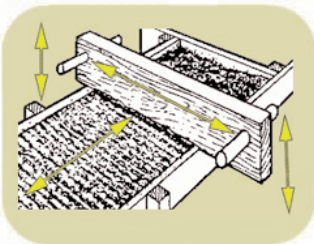

Tap the sides of the formwork with a hammer to help produce a solid edge to the slab. Continue placing layers of concrete into the formwork and compacting until full.

Use the tamping beam with a chopping and sawing motion across the slab, working from one end to the other. This will level off the concrete, leaving it flush with the top of the formwork.



The concrete should be tamped flat as it is poured. After tamping the concrete should be smoothed out with either a wooden or a plastic float - this allows the batons of the floor to sit evenly.

Concrete must not be allowed to dry out too quickly or be damaged by frost whilst wet. Cover with plastic sheeting until the concrete is hard and spray with water for several days to allow it to dry out slowly.

When base is ready, remove the formwork and tidy around the base ready for delivery of your new building. Fill the 6" (150mm) around the edge of your new base with pea shingle to prevent 'splash-back' as rain drips to the floor.

If you encounter any problems with constructing a base. Titan would be pleased to answer any of your questions or provide any advice that would assist your assembly.

Call 01483 451009 or Email info@titangardenbuildings.com
